

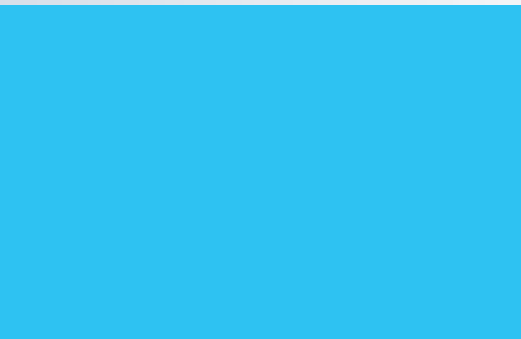

# INDOOR COURTS

quality custom products

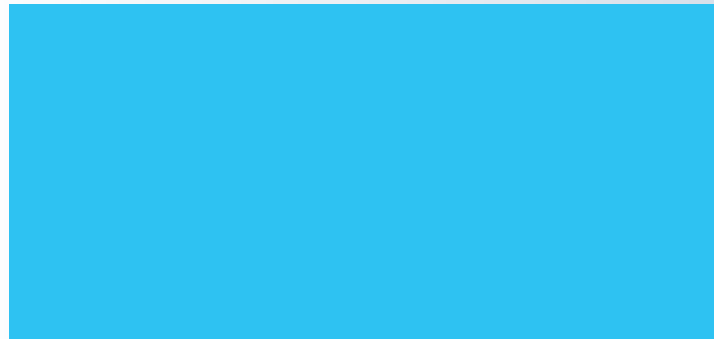

# The Douglas® Advantage

Douglas® is the leading USA manufacturer of custom netting and vinyl products. With over 50 years of custom fabrication experience we have the highest and most strict material specifications in the industry. The diverse line of custom products offered by Douglas® ensures you can find the best material at the best price for any recreational or industrial application. Our sales representatives are highly knowledgeable and provide unparalleled service and support.

## QUALITY

As the manufacturer, we control every aspect of the production process. Every piece of material goes through multiple quality control checks to ensure accuracy and precision. Douglas's meticulous attention to detail guarantees consistent, quality craftsmanship every time.

## SELECTION

Douglas® carries a complete line of premium polypropylene netting and vinyl products. Our sales representatives will gladly guide you through the options and help you select the material that is best suited for your application.

## SERVICE

Our dependable customer service team takes pride in quick response times with most inquiries being answered in no more than 24 hours. Every employee at Douglas® is cross trained on all products to ensure we always have the answers to all your questions. Our goal is your 100% satisfaction and we work relentlessly to exceed your expectations.

## CUSTOMIZATION

Our indoor custom netting and vinyl products are made-to-order per your exact specifications. We can assist with all aspects of your project such as graphic design, layout and drawings. Our meticulous attention to detail will ensure a reliable finished product.

## USA Manufactured

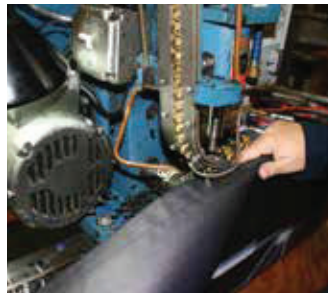

## Digital Printing

Our vinyl fabrics can be customized with a school name, logo, mascot or advertisement. Our material is printed with our high quality UV digital printing process. Our elite printing method allows us to print directly on our materials eliminating the "white back" eye sore as used by other printing companies. We specialize in wide format, multi-color print and can create virtually any design. Once printed, the ink becomes part of the material and will not crack, peel or fade. All print jobs include a complimentary artwork design proof for approval. Once approved, our state of the art digital printer runs the exact blueprint from the artwork proof with laser precision eliminating any chance of error.





## Measuring for Indoor Court Products

Please include all measurements on an overhead drawing similar to below.  
Contact us for additional measurements and installation suggestions.

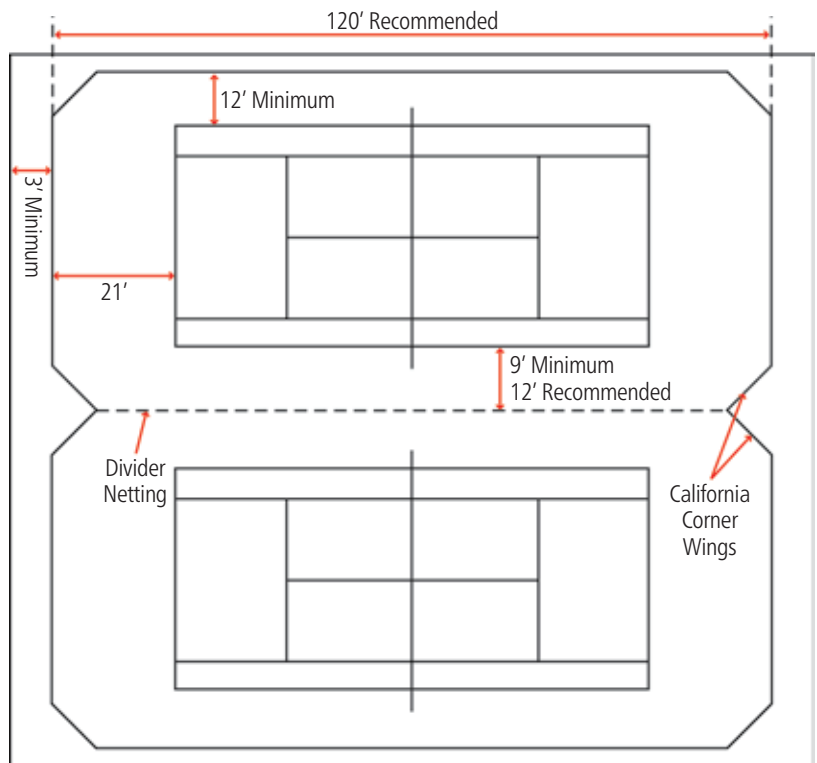

## Complete Line of Tennis and Pickleball Court Construction Products

Nets and Net Posts

Windscreen | Court Divider Netting

Backdrop Curtains | Divider Curtains

Count on Douglas® for the most durable, long lasting USA made Tennis & Pickleball products in the industry. Douglas® has been manufacturing tennis products for over 50 years and offers a wide variety to accommodate not only your facility but your budget too.

# Douglas® Divider Netting

Create a barrier in between courts for uninterrupted play with Douglas® high quality divider nets. Court divider nets are made from high tenacity knotless polypropylene (pylon) and custom fabricated to your facility's required dimensions. We provide both indoor and outdoor court divider netting. Black and green styles are weather treated to withstand moisture and sunlight. Natural white netting is for indoor use only. Kickplates are available for indoor applications in either 12" high Solid Vinyl or 18" high VCP. Kickplates are useful in helping to weight the panels down, and to keep balls from rolling under to ensure uninterrupted play from court to court. Tape borders are double sewn with 1-1/2" reinforced solid vinyl. Heavy-duty brass grommets are spaced 18" along top (standard) Additional grommets may be specified. Standard height is 10', however, any custom height is available.



## ○ #420 Knotless Pylon

This lightweight, pylon netting is ideal for divider netting. #420 Knotless Polypropylene (Pylon) is 1-1/2" square mesh and has a 125# break strength. Choose from Black or White. Weather treated to withstand moisture and sunlight. Netting is finished with a vinyl border and provides the netting with added strength while keeping the nets shape. The reinforced, double stitched vinyl also gives the net a sharp appearance. Optional brass grommets can be added and are placed every 18".

### 1-1/2" SQ Mesh

Lightweight, 125 lb. break strength

Black, Tape Bound with Grommets (Item # 22009)

White, Tape Bound with Grommets (Item # 22005)

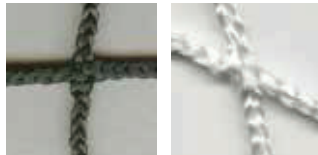

## ○ Prefabricated Divider Panels

These prefabricated divider netting panels measure 10' x 60' and 10' x 65' and can be used indoors or outdoors. Netting in 1-3/4" sq mesh.



## ○ #18 Knotted HDPE

Netting panels are 10' x 60' and can be used indoors or outdoors. This high density Polyethylene (HDPE) netting offers maximum longevity and durability. Panels are constructed of black #18 knotted 1-3/4" sq mesh netting with a 125 lb break strength. This HDPE netting is ideal for low impact applications. Netting is treated and extruded through the fibers for maximum weather and UV resistance. Outside perimeter has a reinforced sewn rope border making it easy to hang.

### 1-3/4" SQ Mesh

Lightweight, 125 lb break strength

10' x 60' (Item # 32014)



## ○ Premium Knotless Polypropylene HTPP

This Premium high tenacity Polypropylene (Pylon) netting offers maximum longevity and durability. Pylon netting is ideal for high impact applications. 3.0 mm has a 250# break strength and is available in Black, Dark Green or White. Netting is treated and extruded through the fibers for maximum weather and UV resistance. Netting is finished with a vinyl border and provides the netting with added strength while keeping the nets shape. The reinforced, double stitched vinyl also gives the net a sharp appearance. Optional brass grommets can be added and are placed every 18".

### 3.0 mm; 1-3/4" SQ Mesh

Medium Weight, 250 lb break strength

Black, Tape Bound with Grommets (Item # 22260)

Dark Green, Tape Bound with Grommets (Item # 22261)

White, Tape Bound with Grommets (Item # 22262)

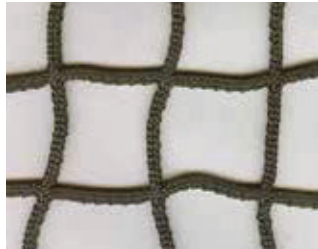

## ○ #420 Knotless Pylon

This black lightweight, pylon netting is ideal for divider netting. #420 Knotless Polypropylene (Pylon) is 1-3/4" square mesh and has a 125# break strength. Netting is weather treated to withstand moisture and sunlight. Netting is finished with a vinyl border and provides the netting with added strength while keeping the nets shape. The reinforced, double stitched vinyl also gives the net a sharp appearance. Brass grommets are spaced every 18".

### 2.0 mm 1-3/4" SQ Mesh

Lightweight, 125 lb break strength

10' x 65' (Item # 32020)



## ○ Replacement Kickplates



VCP Mesh Kickplate - 18" High with Velcro Top



Solid Vinyl Kickplate - 12" High with Velcro Top



Netting Kickplate - 24" High with Velcro Top

# Douglas® Backdrop Curtains

Add or replace your existing backdrop curtains. Solid vinyl backdrop curtains can be installed around the perimeter walls of your facility to provide a visual backdrop for players and aesthetic appeal to onlookers.

All curtains are customized to your specifications and produced from the most durable materials available. Choose from heavy duty 14 oz or 18 oz vinyl in a variety of colors. Besteel 170 Series Walk-draw track systems are available for hanging the curtains. Tracks are constructed of 14 gauge galvanized steel in both suspended and direct mount installation options.



## Available Colors

Additional colors are available upon request. \*10 oz. White FR Vinyl is also available for High-Line Backdrop Curtains (to go above perimeter backdrop curtains)

### 14 OZ. FR VINYL



### 18 OZ. FR VINYL

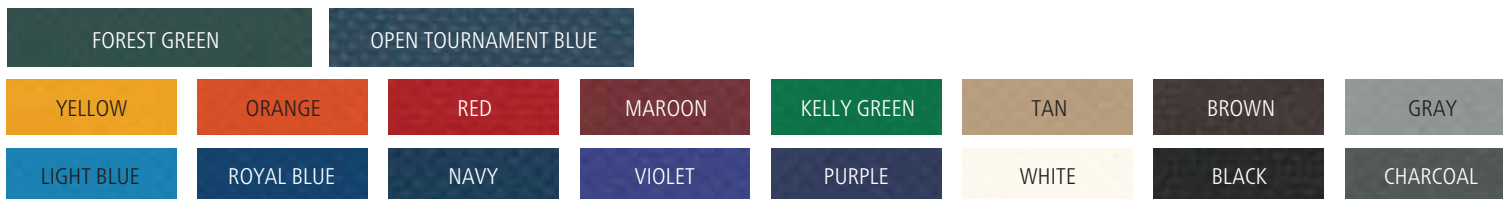

Doors with Viewing Mesh Window



Viewing Mesh Window

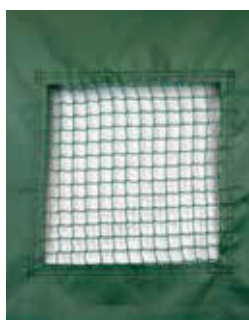

Viewing Net Window

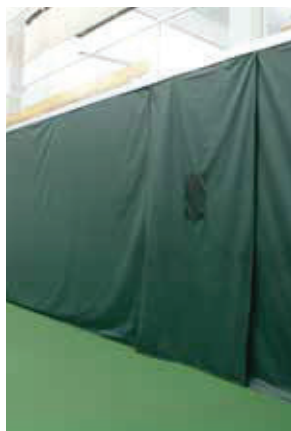

## ○ Curtain Specifications

Backdrop and Gym Divider Curtains are constructed of vinyl coated polyester that is mildew resistant and UV treated. Vinyl material meets California Fire Marshal requirements for flame resistance in indoor use. This strict code meets or exceeds most city requirements. Choose from 14 oz or 18 oz/square yard weights in a variety of colors. 18 oz is recommended for greater durability and life expectancy. For Gym Divider Curtains, the top portion is constructed of FR open weave white vinyl mesh or netting.

## ○ Dimensions

Heights of curtains generally range from 9' to 12' and custom heights are available to meet your needs. The maximum recommended length per curtain is 60'.

## ○ Fabrication

Seams are heat-sealed and reinforced hems are double sewn with lock stitching. Brass grommets are typically spaced every 12" on the top of backdrop curtains. The sides can be sewn with grommets or velcro to attach curtains together or without grommets to overlap curtains instead. Douglas® can accommodate any special requirements such as placement of doorways, ventilation/viewing cut-outs with netting or mesh screen and divider wings.

## ○ Custom Printing

Our vinyl fabrics are digitally printed with our high-quality UV digital printing process. Our elite printing process allows us to print directly on our material so there's no white back side like other digital printing companies. Your printing and logos become part of the material. Your investment will not crack, peel or tear like vinyl decals. Our digital printing allows for more detailed multi-color capabilities and has a quick turnaround and greater accuracy.

# Douglas® Gym Divider Curtains

Add or replace your existing Gym Divider Curtains with Douglas® quality. Gymnasium divider curtains allow you to make the most effective use out of your facility by dividing a large open space into smaller sections for various sports and other events. Divider curtains provide safety, visual privacy and a sound barrier between spaces. Curtains can be custom fabricated with all solid vinyl, partial vinyl/partial netting or mesh. Top of panels are open to allow light and air flow through the netting panels.

Curtains are customized to your specifications and produced from the most durable materials available. Choose from 14 oz or 18 oz vinyl in a variety of colors. Top portion of divider panels are constructed of FR open weave white vinyl mesh or netting. Add custom lettering or graphics of any design with Douglas® high-quality UV digital printing process. Besteel 170 Series Walk-draw track systems are available for hanging the curtains. Tracks are constructed of 14 gauge galvanized steel in both suspended and direct mount installation options.



## Accessories

### ○ Vinyl Court Signs

Constructed of 18 oz vinyl, perimeter is hemmed with grommets.

#### Court Numbers (Item # 22204)

Numbers are from 1 through 20 and measure 9" H. Signs measure 12" x 12"

#### Exit Sign (Item # 22202)

Red vinyl with white letters measuring 9" high. Sign measures 18"H x 36"L



### ○ Installation Accessories

#### Besteel 170 Series Walk-draw Track Systems (Item # 39500)

Available for hanging curtains, these tracks are constructed of 14 gauge galvanized steel in both suspended and direct mount installation options.

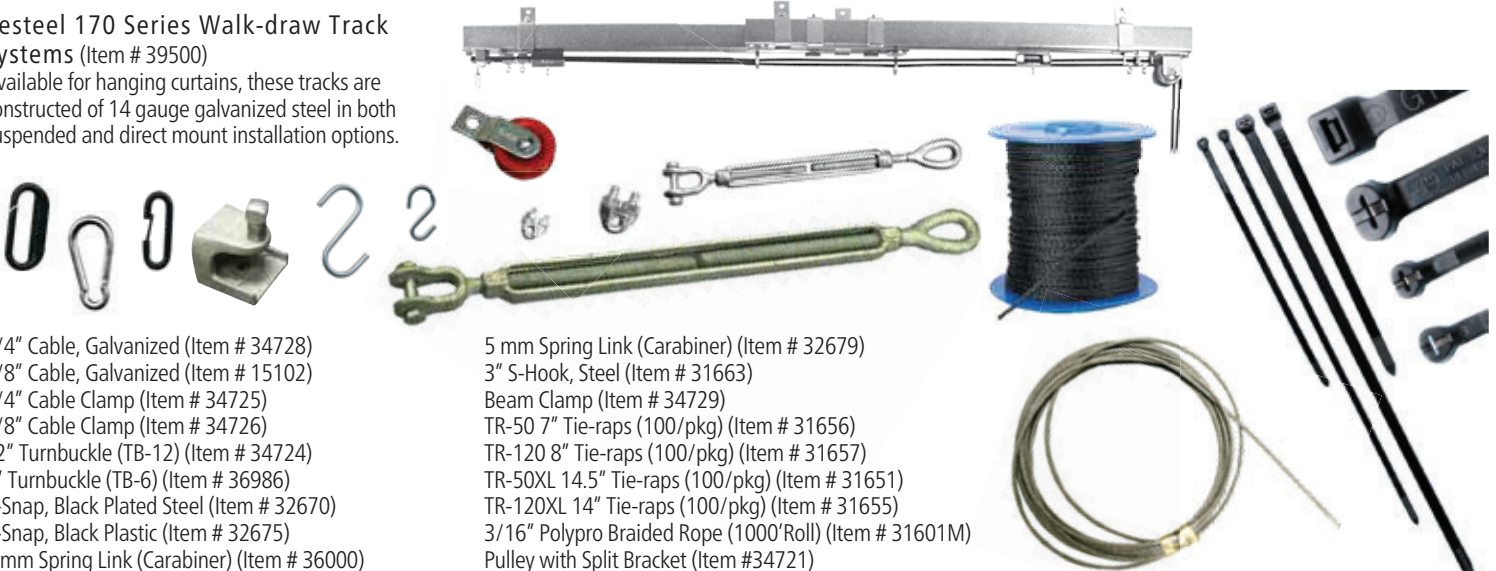

- 1/4" Cable, Galvanized (Item # 34728)
- 1/8" Cable, Galvanized (Item # 15102)
- 1/4" Cable Clamp (Item # 34725)
- 1/8" Cable Clamp (Item # 34726)
- 12" Turnbuckle (TB-12) (Item # 34724)
- 6" Turnbuckle (TB-6) (Item # 36986)
- C-Snap, Black Plated Steel (Item # 32670)
- C-Snap, Black Plastic (Item # 32675)
- 8 mm Spring Link (Carabiner) (Item # 36000)

- 5 mm Spring Link (Carabiner) (Item # 32679)
- 3" S-Hook, Steel (Item # 31663)
- Beam Clamp (Item # 34729)
- TR-50 7" Tie-raps (100/pkg) (Item # 31656)
- TR-120 8" Tie-raps (100/pkg) (Item # 31657)
- TR-50XL 14.5" Tie-raps (100/pkg) (Item # 31651)
- TR-120XL 14" Tie-raps (100/pkg) (Item # 31655)
- 3/16" Polypro Braided Rope (1000' Roll) (Item # 31601M)
- Pulley with Split Bracket (Item # 34721)

# Douglas® Indoor Padding

Protect your players with durable, Douglas® protective padding. All padding is constructed with high-impact foam wrapped in our durable long lasting 14 oz or 18 oz vinyl. Flame resistant vinyl covering meets the state of California Fire Marshall requirements.

## Wall Padding

Standard size panels are 6' high x 2' wide x 2" thick. The high-impact foam is wrapped in durable long lasting vinyl and backed with a 3/4" thick plywood. Flame resistant vinyl cover meets the state of California Fire Marshall requirements. Reinforced double sewn padding attaches top and bottom with either z-clip (#26320) or a 1" lip method (#26325).



Z-Clip Attachment

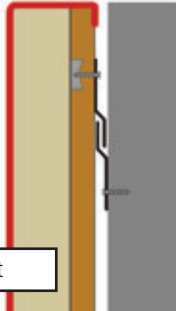

1" Lip Top & Bottom Attachment



## Custom Logo Padding

Our vinyl fabrics can be digitally printed with our high-quality UV digital printing process. Our elite printing process allows us to print directly on our material. Your investment will not crack peel or tear like vinyl decals. Our digital printing allows for more detailed multi-colored capabilities and has a quick turnaround and greater accuracy.



## Custom Sewn Padding

Protective padding that is custom sewn to your specifications. Cushion tapered columns, I-beams, posts or whatever obstacles are in a facility. Durable double sewn padding is 2", 3" or 4" thick high-impact foam with no plywood backing. The high-impact foam is wrapped in durable long lasting vinyl. Flame resistant vinyl cover meets the state of California Fire Marshall requirements. Reinforced double sewn padding can be installed with grommets, velcro or glued on. Measurements and/or drawings must be provided when ordering.

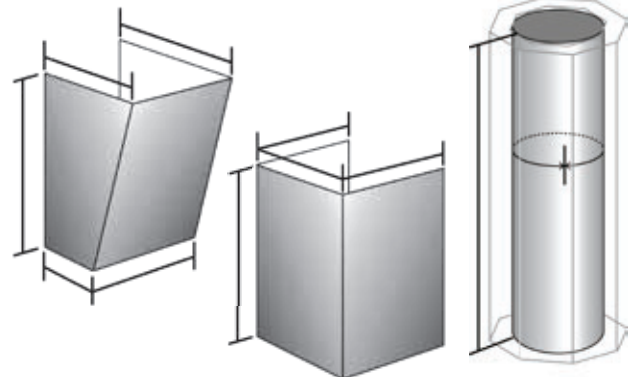

## I-Beam Wrap Pads

Protective I-Beam Wrap Pads that cover the front and sides of the beam face. Standard size panels are 6' high x 2" thick. Padding is for up to a 12" wide beam face; width must be specified when ordering. The high-impact foam is wrapped in durable long lasting vinyl. Flame resistant vinyl cover meets the state of California Fire Marshall requirements. Reinforced double sewn padding attaches with adhesive velcro. Velcro is provided to adhere to backside of beam face.

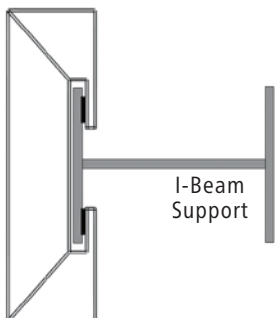

I-Beam Support

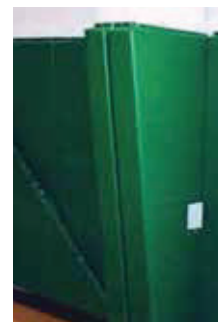

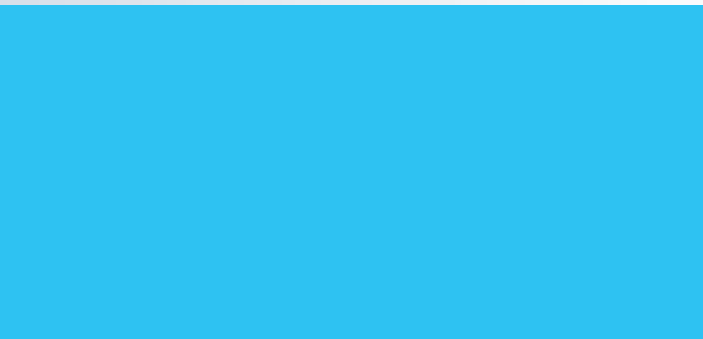
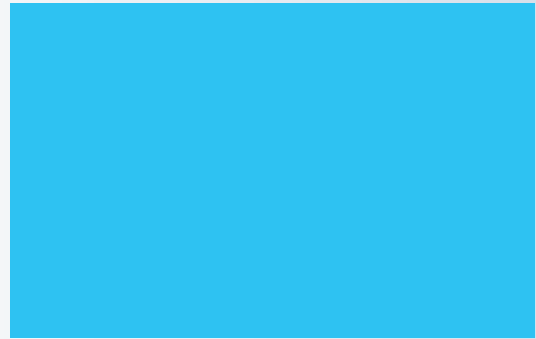
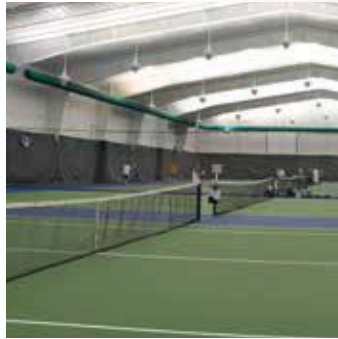

USA MANUFACTURER  
OVER 50 YEARS EST. 1967

1-800-553-8907  
douglas-sports.com