

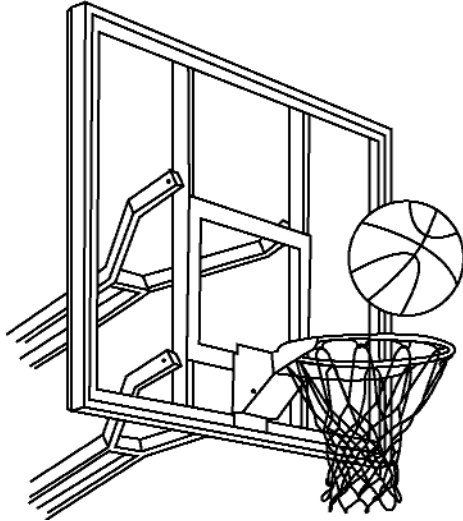

# Pro-434 w/ EZ Crank Installation Instructions



## ! SAFETY INSTRUCTIONS !

Failure to follow these instructions may result in injury or property damage.

*Owner must ensure that all players know and follow these rules for safe operation of this system.*

- The longevity of your Basketball system depends on many conditions such as: the location, the climate, and any exposure to corrosives.
- DO NOT HANG on the rim or any part of the system.
- Do not climb, slide, shake or play on pole.
- When adjusting height be careful of moving parts.
- Do not allow children to move or adjust system. Adult supervision is recommended.
- Serious injury could occur during play activity if teeth/face come in contact with backboard, net, or rim.
- During play, do not wear any jewelry or objects that may get caught in the net.
- Keep pole cap on pole at all times.
- If technical assistance is required please contact Douglas Industries

To ensure safety, please follow the instructions while assembling this system. Proper and complete assembly is essential to ensure for the operation and safety of this system. To reduce any serious injury this system should be properly installed, maintained, and operated. Before beginning, please read and understand the directions.

### Parts List:

#### Step One: Template and Basketball Pole

- 4- Anchor Bolts
- 1- Template
- 8- 5/8" Zinc hex nut
- 4- 5/8" Locknut with nylon insert
- 8- 5/8" zinc flat washers
- Base pole
- Pole cap
- 4- rebar

#### Step 2: Extension Arm and Crank System

- 3- 1/2" x 9" bolts
- 1- 1/2" x 4-1/2" bolt
- 10- 1/2" flat washers
- 14- 1/2" nylon washers
- 4- 1/2" nylon lock nuts
- 1- steel spacers
- 1- upper extension arm
- 1- lower extension arm
- 1- adjustable crank
- 5- height decals

#### Step 3: Backboard and Rim

- Backboard
- Goal Box (parts included)
- 4- 1/2" x 3 1/2" bolts
- 12- 1/2" nylon washers
- 8- 1/2" steel washers
- 4- 1/2" nylon lock nuts

### Suggested Tools and Materials:

- 2-3 people
- Socket Wrenches:  
9/16", 3/4", and 15/16"
- Open End Wrenches:  
9/16", 3/4" and 15/16"
- Small phillips screw driver
- Tape Measure
- Shovel and post hole digger
- Concrete and container mix
- 2- Ladder
- Carpenters Level



Douglas Industries, Inc.  
3441 So. 11th Ave., Eldridge, la 52748  
Toll Free Customer Service: 1-800-553-8907 Fax: 1-800-443-8907  
Email:Sales@douglas-sports.com or Visit us at <http://www.douglas-sports.com>

# Step 1: Template and Basketball Pole

- (A) Ensure ground is level with playing surface. Dig hole 16" wide and 48" deep.



- (B) Assemble mounting plate. Attach 4, 5/8" nuts 2 1/4" from top of anchor bolts. Set template on bolts. Place 4 more 5/8" nuts on top of template. Position anchor bolts as illustrated in Figure 2.
- (C) Pour concrete into the hole 18" from the top. Place four rebars 8" apart forming a square in the center of hole as illustrated in Figure 1.
- (D) Finish pouring concrete into hole. Release air pockets in concrete.
- (E) Drop anchor bolts into the center of the wet concrete until template is flush with cement. Level mounting plate and make sure it's parallel with playing surface. Add 4, 5/8" flat washers on top of nuts. Clean off any excess cement on mounting plate at this time.

**NOTE:** Check leveling of mounting plate several times while concrete is curing. Front of mounting plate must be parallel with playing surface

**IMPORTANT!** Do Not proceed to Step (F) until concrete has cured. A minimum of 72 hours. Allow additional time for cold, wet, or humid weather.

**WARNING!** Two person minimum required for Step (F). Not following this warning may result in an injury and/or property damage.

Figure 1: Concrete Footing

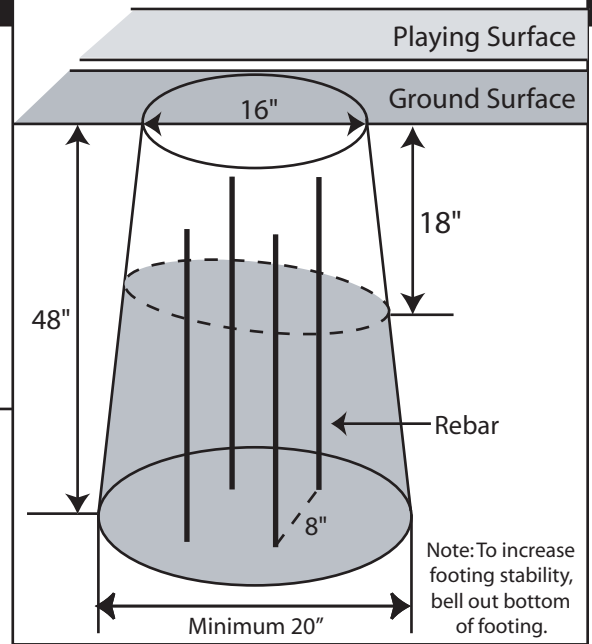
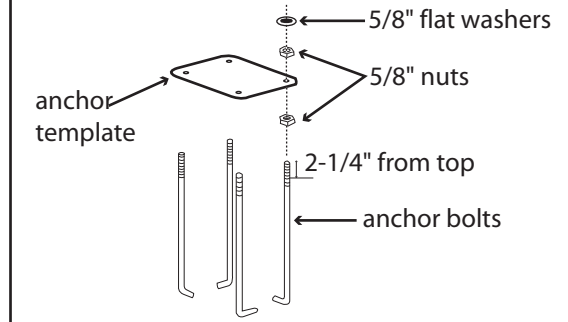

Figure 2: Anchor Plate Assembly



**Anchor System Option:**

As an installation option, you can install the anchor system up to 3" lower than your playing surface. This allows an area to hide the anchor bolts with rock, gravel or mulch.

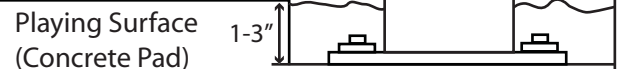
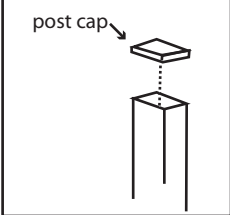

Figure 3: Cap Placement



- (F) Remove basketball pole from box and place post cap on the TOP of the pole.

- (G) Place basketball pole onto the bolts, add 4 5/8" flat washers on top of base plate, then the 4 nylon lock nuts.
- (H) Use level to check for proper vertical alignment, then tighten nylon lock nuts. **NOTE:** Nuts at the top of assembly are used for leveling the system after fully assembled.

Figure 4: Pole Placement

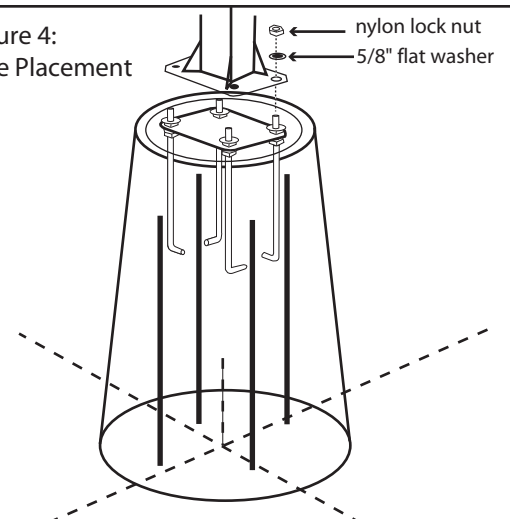

# Step 2: Extension Arms and Crank System

Figure 5: Extension Arms

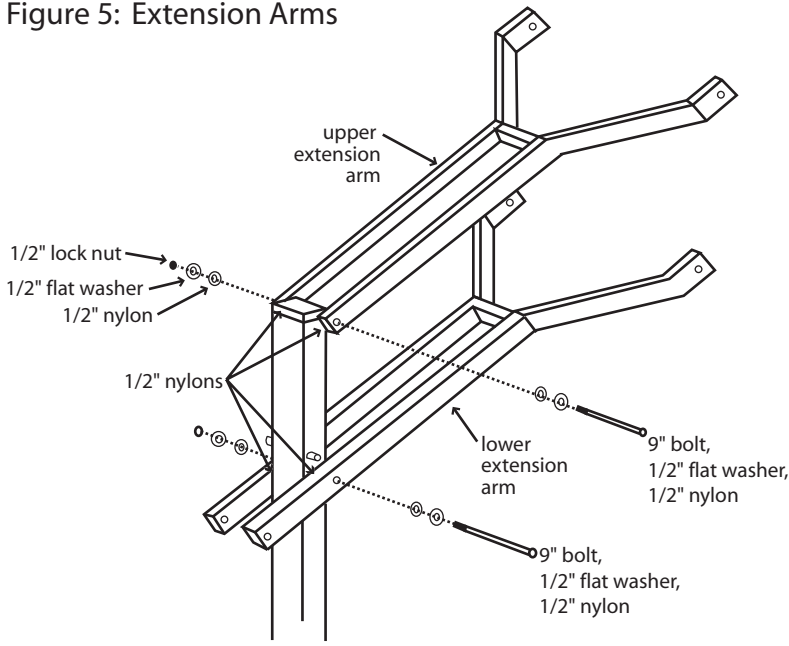

- (A) Locate lower extension arm.
- (B) With 2 people, insert 9" bolt, 1/2" flatwasher, and 1/2" nylon through back of extension arm and into lower welded spacer. In between both arms and the pole (on both sides of pole), place a 1/2" nylon. On the other side of extension arm, finish off with a 1/2" nylon, 1/2" flat washer, and a 1/2" lock nut.
- (C) Locate top extension arm.
- (D) Repeat Step (B)

(See Figure 5 for illustration)

- (E) Locate opening at the top of adjustable crank.
- (F) Line up crank with open holes at the back of lower extension arm. Insert 9" bolt, flat washers and nylon washers as shown and tighten.
- (G) Line up steel spacer at bottom of crank and insert 4-1/2" bolt, flat washers and nylon washers as shown and tighten into crank.

Figure 6: Adjustable EZ Crank

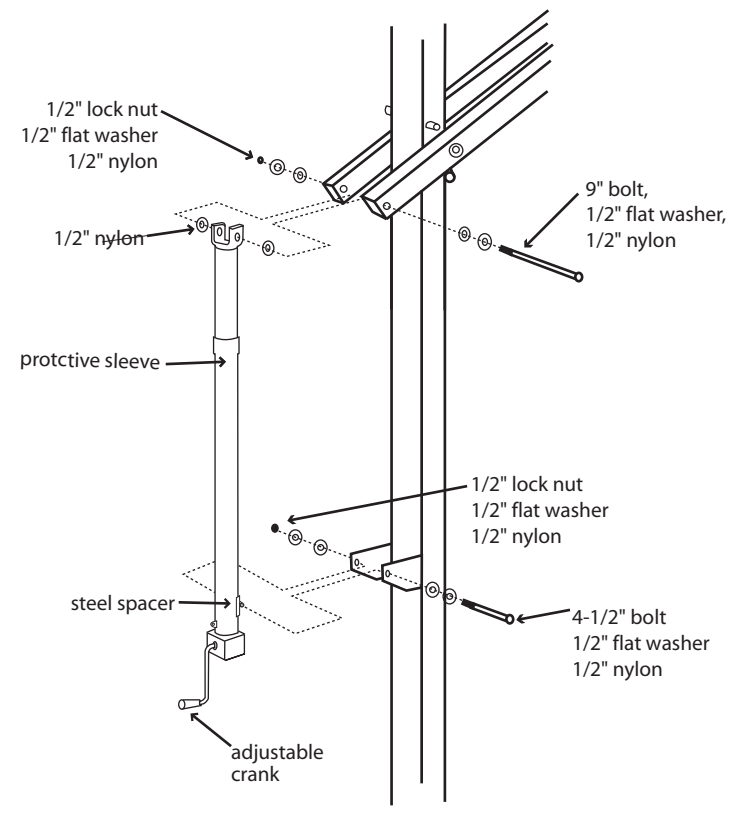

Figure 7: Completed Step 2

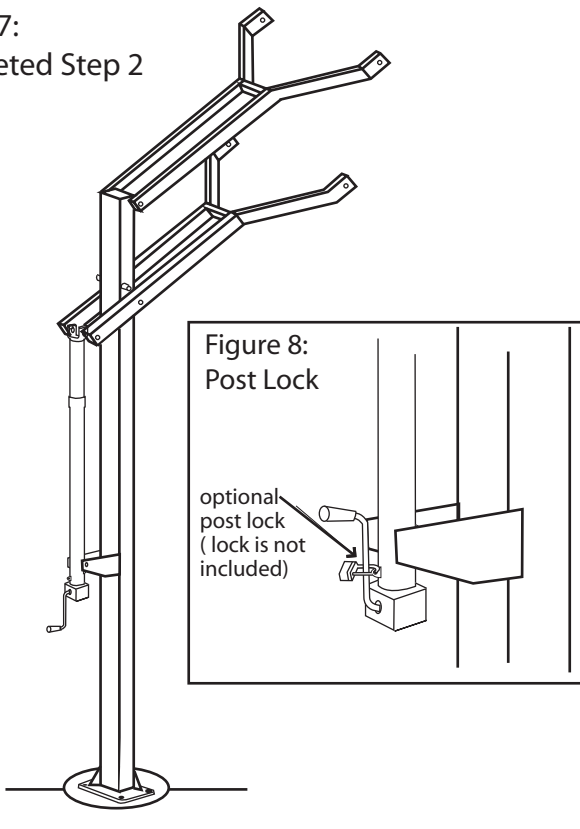
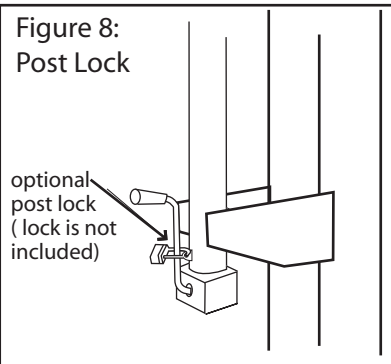

Figure 8: Post Lock



## Step 3: Backboard and Rim

- (A) Lower system to the safety stop.
- (B) With three people, two people hold up the backboard and the third person inserts:
  - 4, 3-1/2" bolts
  - 12, 1/2" nylon washers
  - 8, 1/2" steel flatwashers
  - 4, 1/2" lock nuts

- (C) Locate rim pad, peel off adhesive and place on backboard at rim location
- (D) Assemble rim with enclosed hardware
- (E) Fasten rim cover under rim
- (F) Hang Net
- (G) Check leveling of pole. Pole should be level in all directions.

**Note:** If adjustment is necessary, adjust system by rotating the nuts. After system is level, completely tighten nuts.

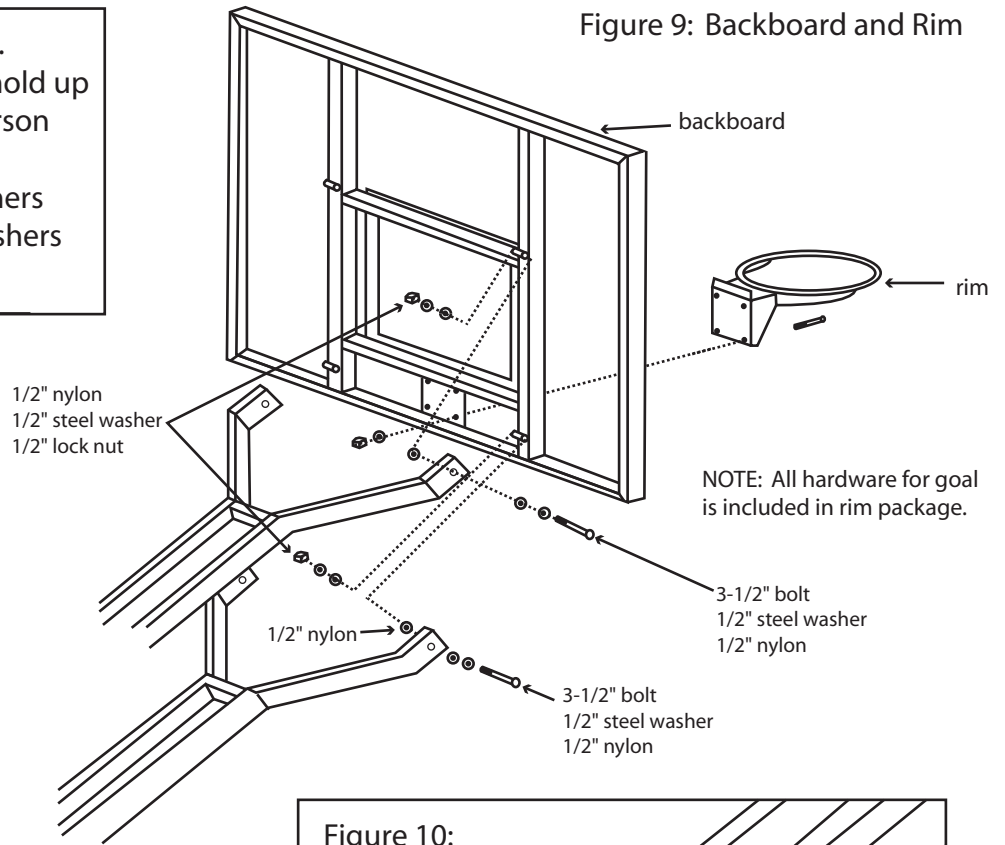
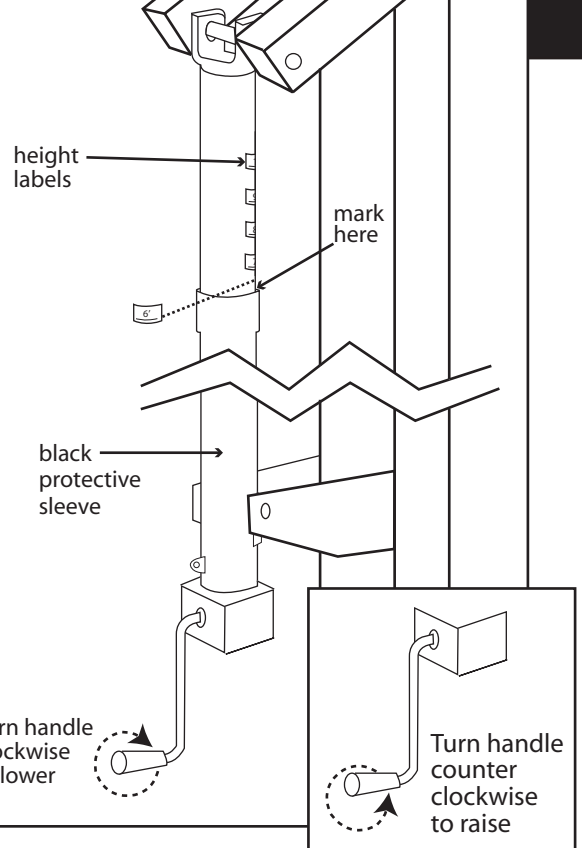

Figure 10:  
Height Adjustment



## Step 4: Height Adjustment Decal

- (A) Raise system to 6' from rim. (Measuring from top of rim to the ground.)
- (B) With a marker, draw a line right above the sleeve on the inside metal part of the crank system. (See Figure 10) **Note:** Placing the decals on the front or sides of the crank may cause them to peel off.
- (C) Raise system to 7' from rim.
- (D) Make another mark at edge of sleeve.
- (E) Continue marking lines at 8', 9' and 10'
- (F) Place provided numerical decals on the galvanized steel to align with the designated height measurement marks. **Note:** For accuracy, the black line on the decal under the numbers should match up with the determined marker height.
- (G) Height should now be set. Adjust if needed. **Note:** Regulation rim height is 10 feet.