

# 75' BATTING TUNNEL FRAME INSTALLATION INSTRUCTIONS (66124)

UNITS	REF #	DESCRIPTION	TOOLS NEEDED
8	1	Corner pole 4" square steel x 14'	1/4" Bolt cutter
8	2	Corner pole collar 4-1/2" sq. x 4"	9/16" Wrench (1)
4	3	End crossbar 2" O.D. x 14' 8-5/8"	7/16" Wrench (2)
8	4	Black top cap	13' Ladder (2 recommended)
8	7	24" Aluminum square ground sleeve for 4" sq pole	
12	9	Chain hook	
12		Steel c-snaps	
80		Plastic c-snaps	
250'		Chain	

**FIGURE 1**

ALL DISTANCE MEASUREMENTS ARE FROM CENTER TO CENTER:

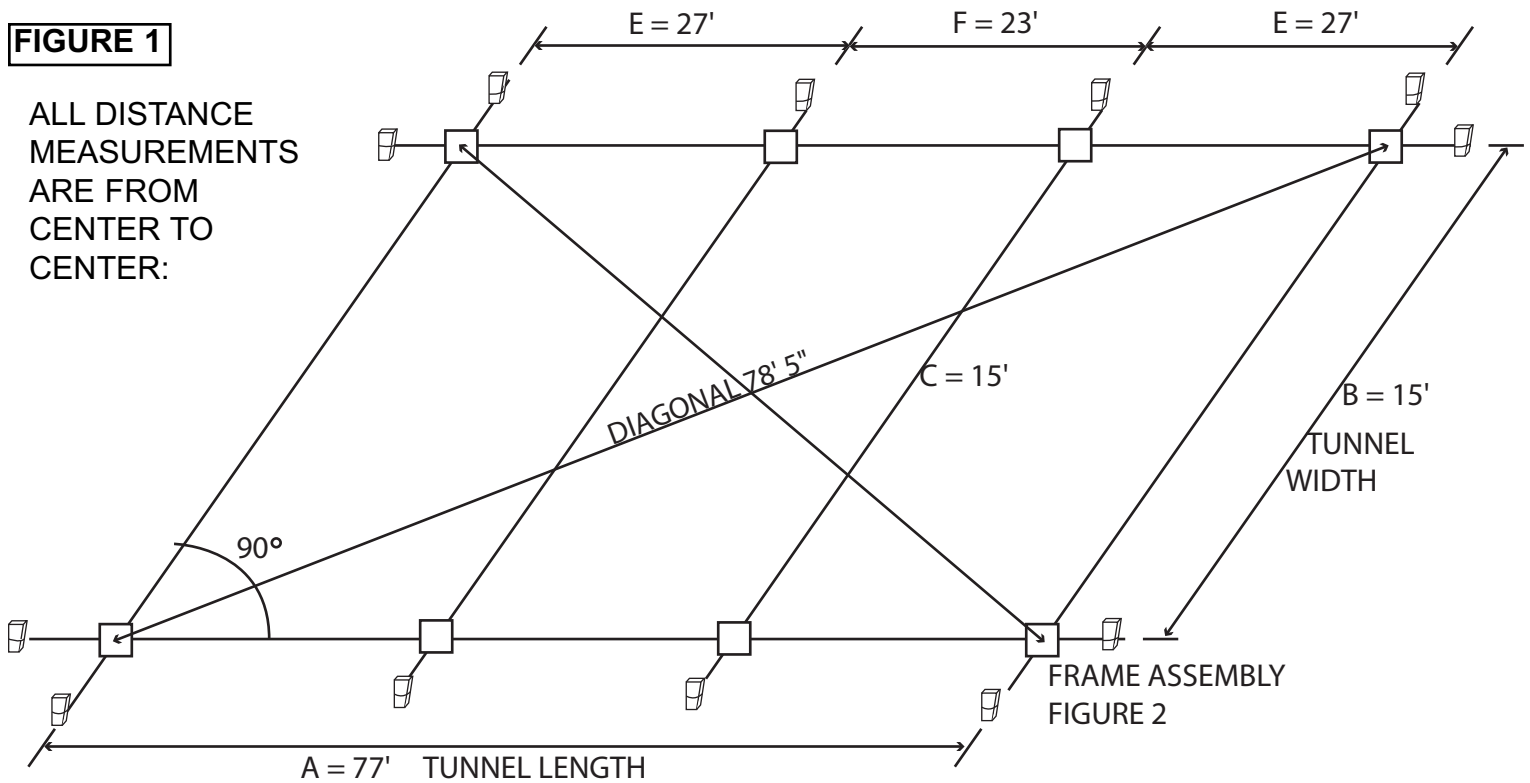

**Step 1** Locate corner and center pole locations as per Figure 1. Measure distances from center to center.

**Step 2** Dig one corner footing as shown in Figure 2 (36" minimum) and pour concrete in footing hole 2/3 full. Place aluminum steel ground sleeves (ref #7) in concrete making sure the sleeve is square with the other three corner poles. Again, distances are from center to center.

**Step 3** Fill hole with concrete around sleeve up to ground level. Ground sleeve should be flush with top of concrete and straight.

**Step 4** Repeat steps 1-3 for remaining ground sleeves.

# 75' BATTING TUNNEL FRAME INSTALLATION INSTRUCTIONS(66214)

**FIGURE 2**

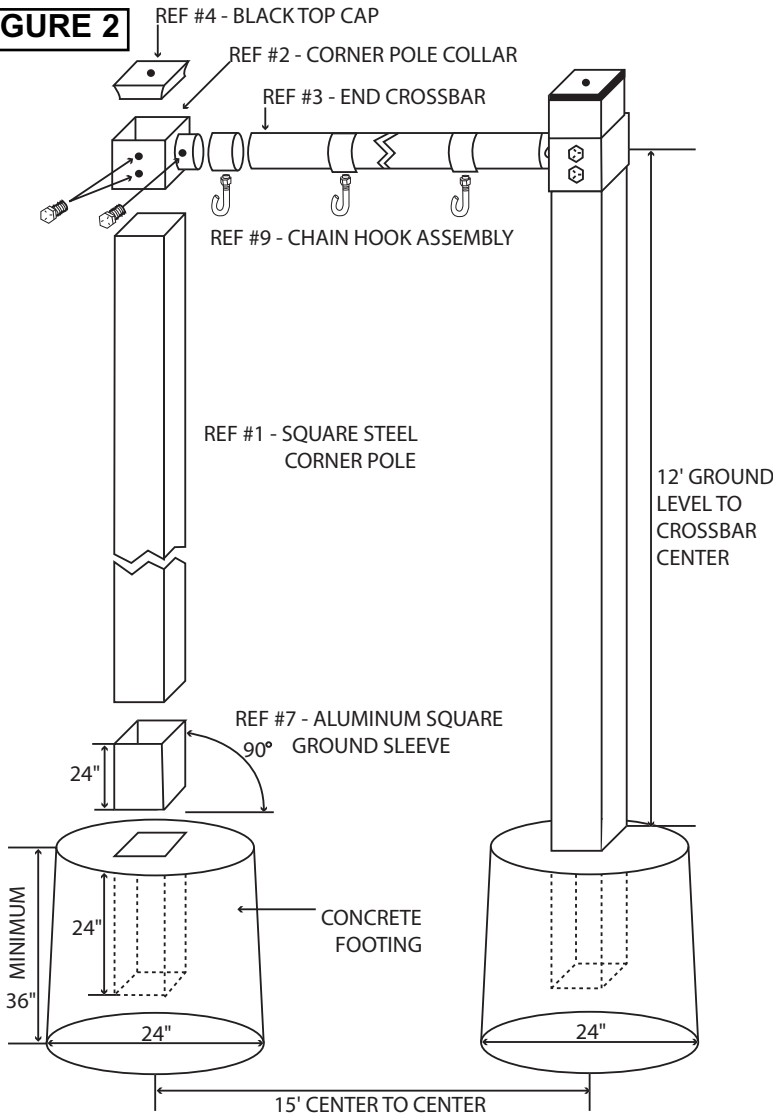

**Step 1** Unroll the net and lay on the ground inside the frame. Locate the top border rope.

**Step 2** Cut 3 pieces of chain to at least 80' lengths. Using the steel c-snaps, attach the chain to the chain hooks across the four crossbars. One piece for each side and one down the middle. Take out as much slack as possible. Have a minimum of 1' of chain on each end for adjustment when suspending the net.

**Step 3** Starting at one corner attach the net to the chain using the plastic s-snaps. Start approximately 2' from the end cross bar. Continue down the net, placing a plastic c-snap every 3'. Next, attach the middle rope by starting on the outside for the end c-snap and then move to the inside of the tunnel for the remaining c-snaps. Repeat for the last chain.

**NOTE:** Taking the slack out of the chain will raise the net. Increasing the slack in the chain will lower the net.

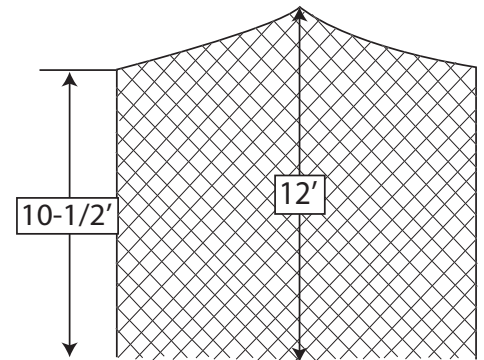
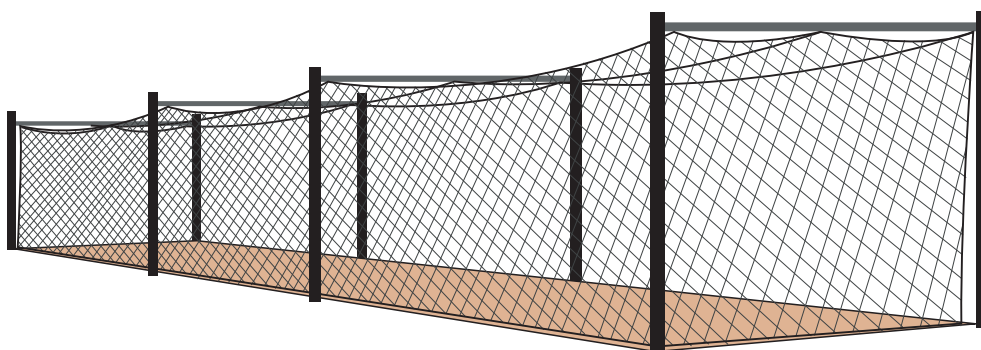

**BATTERS VIEW OF CAGE**

Note: The "slope" of the net is important. The center of the net, for it's entire length is 12' high. The sides of the net are only 10 1/2' high, leaving 18" of net on ground to keep batted balls inside the enclosed area.